

FINAL EXAMINATION

**Networked Life
CIS 112
Prof Michael Kearns**

May 5, 2009

This is a closed-book examination. You should have no materials on your desk other than this exam and a pen or pencil. If you need more space to answer a problem, use the reverse side of the same page and clearly indicate you have done so.

YOUR NAME: _____

Problem 1 _____/10

Problem 2 _____/10

Problem 3 _____/10

Problem 4 _____/10

Problem 5 _____/10

Problem 6 _____/10

Problem 7 _____/10

Problem 8 _____/20

Problem 9 _____/10

TOTAL: _____/100

Problem 1 (10 Points) For each item on the left, write the index of the item on the right which matches best.

- | | |
|--|--|
| a. minority power ____ | 1. alpha model |
| b. frequency of English words ____ | 2. Arrow & Debreu |
| c. rubber necking ____ | 3. biased voting experiments |
| d. generates high clustering & small diameter ____ | 4. no one can unilaterally improve his payoff |
| e. Kleinberg-esque network formation game ____ | 5. efficient navigation when $r = 2$ |
| f. an abstract commodity ____ | 6. the ultimatum game (nearly all cultures) |
| g. generates low clustering & small diameter ____ | 7. preferential attachment |
| h. behavioral game theory ____ | 8. money |
| i. Nash equilibrium ____ | 9. a.k.a. the social channel capacity |
| j. navigation in a small world ____ | 10. networks of constant diameter for $a \leq 2$ |
| k. Paris Metro Pricing ____ | 11. Zipf's law |
| l. inequality aversion ____ | 12. bounded rationality |
| m. theory of efficient markets ____ | 13. yet another unfortunate equilibrium |
| n. consensus ____ | 14. decongestion through differential pricing |
| o. magic number 150 ____ | 15. a game that's the opposite of coloring |

Problem 2 (10 points)

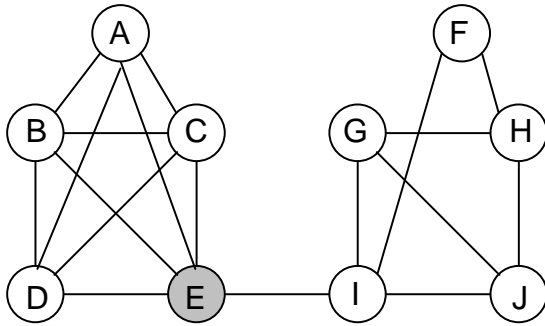

(Left)

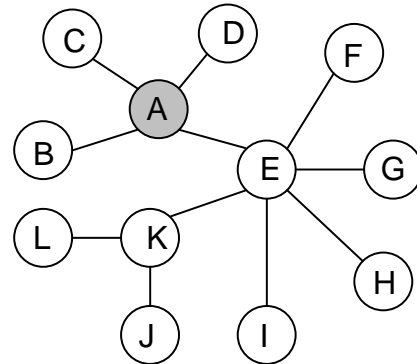

(Right)

For the “left” and “right” networks above:

(a) Write the letter of the vertex with the highest degree and give its degree.

Left: _____ Right: _____

(b) State the size of the worst case diameter.

Left: _____ Right: _____

(c) State whether the network is bipartite.

Left: _____ Right: _____

(d) Give the clustering coefficient of the gray colored vertex.

Left: _____ Right: _____

(e) State which model --- Erdos-Renyi, preferential attachment, or the alpha model --- was most likely to have generated the network.

Left: _____ Right: _____

Problem 3 (10 points) For the networks below, write the equilibrium in the space beside each vertex, assuming all vertices are initially endowed with one unit of milk or wheat and have preferences only for the other good.

(a)

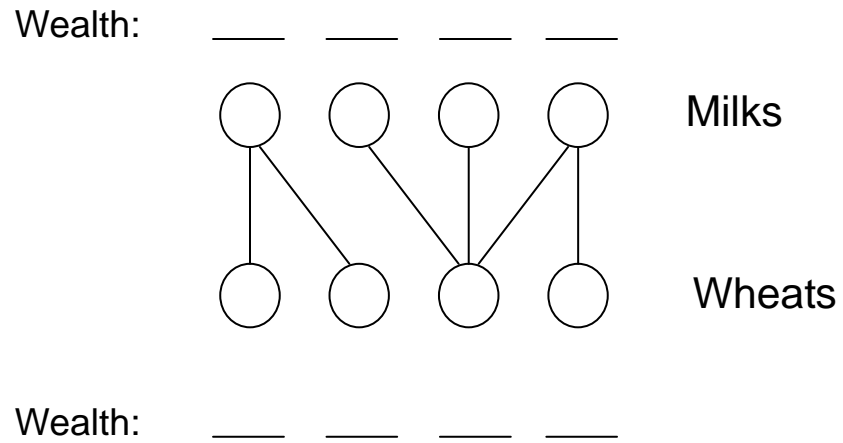

(b)

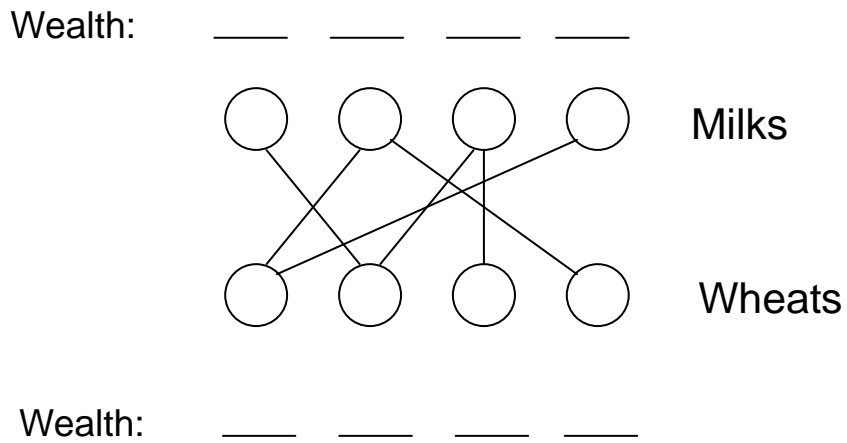

Problem 4 (10 points) Briefly discuss two problems or protocols arising on the Internet whose formulation or solution involves game-theoretic or economic considerations. For each, clearly identify the parties involved, their individual incentives, and how those incentives interact to create strategic tension. Describe any underlying technological facts (e.g. how a protocol is designed to work) needed to explain these strategic tensions.

Problem 5 (10 points) Describe and discuss two games (in the formal sense of game theory) in which it is known that human subject behavior deviates from equilibrium predictions, and discuss the nature of this deviation.

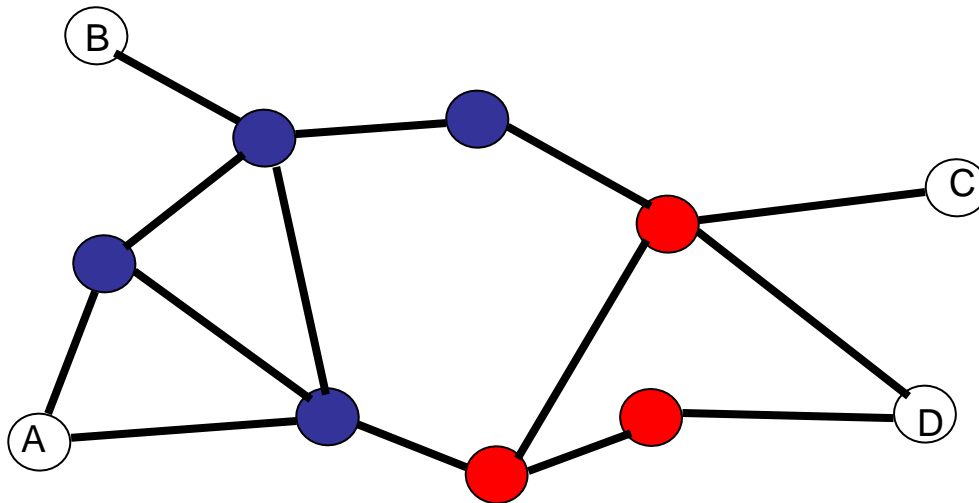

Problem 6 (10 points) The network diagram above shows 4 Internet end-users: A, B, C and D. Users A and B have their Internet service provided by Provider Blue, who operates the routers shown in blue, while users C and D have their Internet service provided by Provider Red, who operates the red routers. Providers Red and Blue operate independently, and each has the incentive to get traffic destined for parties on the other network off of their own network as quickly as possible (that is, with the fewest router hops --- “early-exit” routing).

Will the combined early-exit routing behavior of Providers Red and Blue guarantee that all traffic between all pairs of end users will always travel on a *globally* shortest path? Answer yes or no. If your answer is no, give a specific counterexample to global optimality, clearly annotating the diagram with both the path actually taken and the globally shortest path.

Problem 7 (10 points) The image below is reproduced from the required reading “Behavioral Experiments on Biased Voting in Networks”, which was also discussed in class.

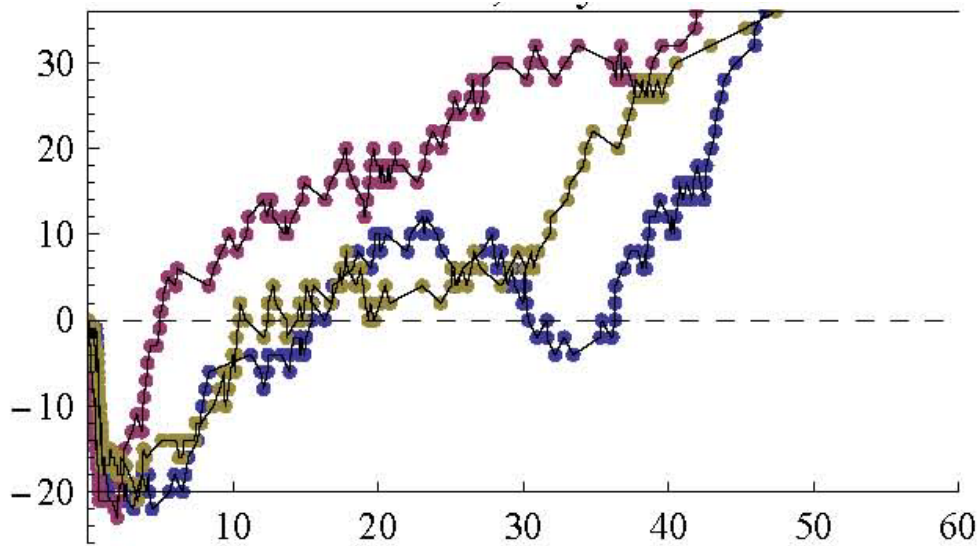

(a) Clearly describe what is being plotted in this diagram --- i.e. what is measured by the x-axis and the y-axis. Be as precise and complete as you can --- for instance, your answer should make it clear why there can be negative y values.

(b) What network structure was underlying the experiments represented in the diagram? What interesting behavioral phenomenon do the plots show?

Problem 8 (20 points). For this problem you are asked to reconsider the network formation game introduced in the last problem of Homework 3. To review: Consider a network formation game in which each of N players may purchase edges from their own vertex to other players for a fixed cost of c per edge. Let G denote the network formed by the collective edge purchases of all players. The overall payoff to a given player X is then equal to the *number of players X is connected to in G , minus the total edge expenditures of player X* . By “connected to”, we mean reachable by any finite-length path. Note that we view this as a one-shot game, in which all players simultaneously decide which edges to purchase.

- (a) Consider a network that is a simple cycle over the N players. Are there values for the edge cost c such that this network is an equilibrium of the formation game? If not, why not? If so, which value(s) of c ?

- (b) Consider a network that is a line or chain over the N players:

1 --- 2 --- 3 --- 4 --- 5 --- ... --- $N-1$ --- N

Suppose that $c = N/4$. Is it possible for this network to be an equilibrium? If not, why not? If so, describe who would purchase which edges at equilibrium.

(c) Repeat part (b) but for edge cost $c = 3N/4$.

(d) Suppose that $c = 6$ and that N is very large. Consider the “universal” structural properties of social networks we discussed in the first half of the course: small diameter, heavy-tailed degree distributions and high clustering coefficient. For each of these properties, briefly discuss whether the equilibrium networks of the formation game *must always* have the property, *may sometimes* have the property, or *will never* have the property.

Problem 9 (10 points) Briefly describe Braess' Paradox, illustrating it in a simple network diagram with whatever annotations you need. Why is it called a paradox?